

# Turbochargers

<b>Common Terms .....</b>	<b>2</b>
Adiabatic Efficiency .....	2
Pressure Ratio .....	2
Density Ratio .....	2
Turbine .....	2
A/R Ratio .....	2
Charge-Air-Cooler .....	2
Boost .....	2
Waste Gate .....	2
Turbo Lag .....	3
Boost Threshold .....	3
Turbo Cool down .....	3
<b>Selecting a Turbocharger Compressor.....</b>	<b>4</b>
Engine Air Flow Requirements .....	4
Pressure Ratio .....	4
Temperature Rise .....	4
Adiabatic Efficiency .....	5
Density Ratio .....	5
Compressor Inlet Airflow .....	5
<b>Camshafts for Turbocharged Engines .....</b>	<b>6</b>
Pressure Differential.....	6
Valve Overlap.....	6
Valve Lift .....	7
Roller Camshafts.....	7
<b>Turbocharger Exploded View.....</b>	<b>8</b>
<b>Turbocharger Troubleshooting Chart .....</b>	<b>9</b>

# Common Terms

Source: [www.grapeaperacing.com](http://www.grapeaperacing.com)

---

## Adiabatic Efficiency

A 100% adiabatic efficiency means that there is no gain or loss of heat during compression. Most turbochargers will have a 65-75% adiabatic efficiency. Some narrow range turbo's can get higher; these types of turbo's generally work well in engines that operate over a narrow rpm range. In general the wide range turbo's don't have as good peak efficiency, but have better average efficiency and work better on engine that operate over a wide rpm range.

## Pressure Ratio

This is the inlet pressure compared to the outlet pressure of the turbocharger's compressor. For single stage turbo's, the inlet pressure will usually be atmospheric (14.7 psi) and the outlet will be atmospheric + boost pressure. The inlet pressure can be, and usually is slightly below atmospheric. This is due to any restriction in the air cleaner and intake plumbing up to the turbo.

For staged turbo's the inlet pressure will be the outlet pressure of the turbo before it + atmospheric, and the outlet will be inlet pressure + additional boost from that turbo. Staged turbo's are common in high boost applications like tractor pulling engines.

## Density Ratio

Turbochargers compress the air to make it denser, this is what allows more oxygen in the engine and give the potential to make more power. The density of the inlet air compared to the density of the outlet air is the density ratio.

## Turbine

The turbine side of the turbocharger is what converts the energy of the exhaust into mechanical energy to turn the compressor. It consists of the turbine housing and turbine wheel.

## A/R Ratio

The A/R ratio is the area compared to the radius of the compressor or turbine housing. Larger A/R ratios will flow more.

A smaller A/R on the turbine will spool the turbo faster, but become more restrictive at higher rpm. If you use a large turbine A/R ratio for top-end performance, the turbo will take longer to spool up. Turbine A/R is critical to performance. Street engines work best if they have low-end boost, meaning a conservative A/R ratio on the turbine.

On the compressor side, you want to keep the rpm in or near the peak efficiency island as much as possible. The A/R ratio has an effect on where this point is. There are a lot of compressor maps available, so choosing a compressor housing and trim is just a matter of matching it to your flow needs.

## Charge-Air-Cooler

Also known as an intercooler and is nothing more than a heat exchanger. When intake air is compressed by a turbocharger it is also heated. Hot intake air is not good for power and will increase the chance of detonation. A charge-air-cooler reduces the intake temperature; it absorbs some of the heat out of the charge. With less heat, you'll need less boost pressure to get the desired power and decrease the chance of detonation. Anything that reduces the intake temperature is a big plus in a supercharged engine.

## Boost

Usually measured in pounds per square inch, it is the pressure the turbocharger makes in the intake manifold. One of the ways to increase airflow through a passage is to increase the pressure differential across the passage. By boosting the intake manifold pressure, airflow into the engine will increase, making more power potential.

## Waste Gate

The waste gate is a valve that allows the exhaust gasses to bypass the turbine. Most waste gates rely on boost pressure to open them, although some are controlled electronically. The most common ones you'll see today are activated by a spring-loaded diaphragm. The spring holds the gate closed, when there is enough boost pressure behind the diaphragm to overcome spring force, the waste gate opens.

The simplest of boost controllers simply bleed off boost pressure to the waste gate. You can

install a "Tee" fitting in the waste gate actuator hose with a valve that bleeds boost pressure back to the air cleaner. The more the valve is opened, the high boost pressure will be.

## Turbo Lag

A turbocharger uses a centrifugal compressor, which needs rpm to make boost, and it is driven off the exhaust pressure, so it cannot make instant boost. It is especially hard to make boost at low rpm. The turbo takes time to accelerate before full boost comes in; it is this delay that is known as turbo lag. To limit lag, it is important to make the rotating parts of the turbocharger as light as possible. Larger turbo's for high boost applications will also have more lag than smaller turbo's, due to the increase in centrifugal mass. Impeller design, and the whole engine combo also have a large effect on the amount of lag. Turbo lag is often confused with the term boost threshold, but they are not the same thing, lag is nothing more than the delay from when the throttle is opened to the time noticeable boost is achieved.

## Boost Threshold

Unlike turbo lag, which is the delay of boost, boost threshold is the lowest possible rpm at which there can be noticeable boost. A low boost threshold is important when accelerating from very low rpm, but at higher rpm, lag is the delay that you feel when you go from light to hard throttle settings.

## Turbo Cool down

A turbocharger is cooled by engine oil, and in many cases, engine coolant as well. Turbo's get very hot when making boost, when you shut the engine down the oil and coolant stop flowing. If you shut the engine down when the turbo is hot, the oil can burn and build up in the unit (known as "coking") and eventually cause it to leak oil (this is the most common turbocharger problem). Oil coking can also starve the turbo for oil by blocking the passages. It is a good idea to let the engine idle for at least 2 minutes after any time you ran under boost. This will cool the turbo down and help prevent coking.

---

Source: [www.grapeaperacing.com](http://www.grapeaperacing.com)

# Selecting a Turbocharger Compressor

Source: [www.grapeaperacing.com](http://www.grapeaperacing.com)

---

## Engine Air Flow Requirements

In order to select a turbocharger, you must know how much air it must flow to reach your goal. You first need to figure the cubic feet per minute of air flowing through the engine at maximum rpm. The formula to figure this out for a 4-stroke engine is:

$$(CID \times RPM) \div 3456 = CFM$$

For a 2-stroke engine it is:

$$(CID \times RPM) \div 1728 = CFM$$

Lets assume that you are Turbocharging a 350 cubic inch engine that will redline at 6000 rpm. The formula will look like this:

$$(350 \times 6000) \div 3456 = 607.6 \text{ CFM}$$

The engine will flow 607.6 CFM of air assuming a 100% volumetric efficiency. Most street engines will have an 80-90% VE, so the CFM will need to be adjusted. Lets assume our 350 has an 85% VE. When will then need to take that into account as well. The complete formula would look like this:

$$(CID \times RPM \times VE\%) \div 3456 = CFM$$

For our 350, it would look like this:

$$(350 \times 6000 \times 0.85) \div 3456 = 516.5 \text{ CFM}$$

Our 350 will actually flow 516.5 CFM with an 85% VE. That is the first step; to know how much volume the turbocharger will need to flow

## Pressure Ratio

The pressure ratio is simply the pressure in compared to the pressure out of the turbocharger. The pressure in is usually atmospheric pressure, but may be slightly lower if the intake system before the turbo is restrictive, the inlet pressure could be higher than atmospheric if there is more than 1 turbocharger in series. In that case the inlet pressure will be the outlet pressure of the turbo before it. If we want 10 psi of boost with atmospheric pressure as the inlet pressure, the formula would look like this:

$$(10 + 14.7) \div 14.7 = 1.68:1 \text{ pressure ratio}$$

## Temperature Rise

A compressor will raise the temperature of air as it compresses it. As temperature increases, the volume of air also increases. There is an ideal temperature rise, which is a temperature rise equivalent to the amount of work that it takes to compress the air. The formula to figure the ideal outlet temperature is:

$$T_2 = T_1 (P_2 \div P_1)^{0.283}$$

Where:

$T_2$  = Outlet Temperature °R

$T_1$  = Inlet Temperature °R

°R = °F + 460

$P_1$  = Inlet Pressure Absolute

$P_2$  = Outlet Pressure Absolute

Lets assume that the inlet temperature is 75° F and we're going to want 10 psi of boost pressure. To figure  $T_1$  in °R, you will do this:

$$T_1 = 75 + 460 = 535^\circ\text{R}$$

The  $P_1$  inlet pressure will be atmospheric in our case and the  $P_2$  outlet pressure will be 10 psi above atmospheric. Atmospheric pressure is 14.7 psi, so the inlet pressure will be 14.7 psi, to figure the outlet pressure add the boost pressure to the inlet pressure.

$$P_2 = 14.7 + 10 = 24.7 \text{ psi}$$

For our example, we now have everything we need to figure out the ideal outlet temperature. We must plug this info into our formula to figure out  $T_2$ :

$$T_1 = 75$$

$$P_1 = 14.7$$

$$P_2 = 24.7$$

The formula will now look like this:

$$T_2 = 535 (24.7 \div 14.7)^{0.283} = 620^\circ\text{R}$$

You then need to subtract 460 to get °F, so simply do this:

$$620 - 460 = 160^\circ\text{F Ideal Outlet Temperature}$$

This is an ideal temperature rise of 85 °F. If our compressor had a 100% adiabatic efficiency, this is what we'd expect outlet temperature to be. Since it will not have a 100% adiabatic efficiency, we need to do some more figuring.

## Adiabatic Efficiency

The above formula assumes a 100% adiabatic efficiency (AE), no loss or gain of heat. The actual temperature rise will certainly be higher than that. How much higher will depend on the adiabatic efficiency of the compressor, usually 60-75%. To figure the actual outlet temperature, you need this formula:

$$\text{IOTR} \div \text{AE} = \text{AOTR}$$

Where:

IOTR = Ideal Outlet Temperature Rise

AE = Adiabatic Efficiency

AOTR = Actual Outlet Temperature Rise

Lets assume the compressor we are looking at has a 70% adiabatic efficiency at the pressure ratio and flow range we're dealing with. The outlet temperature will then be 30% higher than ideal. So at 70% it using our example, we'd need to do this:

$$85 \div 0.7 = 121 \text{ °F Actual Outlet Temperature Rise}$$

Now we must add the temperature rise to the inlet temperature:

$$75 + 121 = 196 \text{ °F Actual Outlet Temperature}$$

## Density Ratio

As air is heated it expands and becomes less dense. This makes an increase in volume and

flow. To compare the inlet to outlet airflow, you must know the density ratio. To figure out this ratio, use this formula:

$$(\text{Inlet } ^\circ\text{R} \div \text{Outlet } ^\circ\text{R}) \times (\text{Outlet Pressure} \div \text{Inlet Pressure}) = \text{Density Ratio}$$

We have everything we need to figure this out. For our 350 example the formula will look like this:

$$(535 \div 656) \times (24.7 \div 14.7) = 1.37 \text{ Density Ratio}$$

## Compressor Inlet Airflow

Using all the above information, you can figure out what the actual inlet flow in CFM. To do this, use this formula:

$$\text{Outlet CFM} \times \text{Density Ratio} = \text{Actual Inlet CFM}$$

Using the same 350 in our examples, it would look like this:

$$516.5 \text{ CFM} \times 1.37 = 707.6 \text{ CFM Inlet Air Flow}$$

That is about a 37% increase in airflow and the potential for 37% more horsepower. When comparing to a compressor flow map that is in Pounds per Minute (lbs/min), multiply CFM by 0.069 to convert CFM to lbs/min.

$$707.6 \text{ CFM} \times 0.069 = 48.8 \text{ lbs/min}$$

Now you can use these formulas along with flow maps to select a compressor to match your engine. You should play with a few adiabatic efficiency numbers and pressure ratios to get good results. For twin turbo's, remember that each turbo will only flow 1/2 the total airflow.

---

Source: [www.grapeaperacing.com](http://www.grapeaperacing.com)

# Camshafts for Turbocharged Engines

Source: [www.grapeaperacing.com](http://www.grapeaperacing.com)

---

## Pressure Differential

Unlike a supercharger that is driven directly from the crankshaft, a turbo is driven by exhaust gas velocity. Turbochargers are an exhaust restriction (which raises the exhaust gas pressure), but since they use energy that would otherwise be wasted, they are much more efficient than a belt driven supercharger.

Normally when the exhaust valve opens, there is still useable pressure in the cylinder that needs to be dumped so it will not resist the piston trying to go back up the bore. That pressure makes high exhaust gas velocity. With a turbocharged engine, this is the energy that is used to spin the turbine.

With a well-matched turbo / engine combo, boost pressure should be higher than exhaust gas pressure at the low side of the power band (near peak torque). As the engine nears peak hp, the pressure differential will get nearer 1:1. At some point the pressures in the intake and exhaust will be equal, then crossover making the exhaust a higher pressure than the intake. At peak hp there will usually be more exhaust gas pressure than boost pressure. The ultimate goal is to have as little exhaust backpressure possible for the desired boost.

If the turbocharger is matched well to the engine combination, the camshaft selection will not need to be much different than that of a supercharged engine. The problem is that most factory turbo engines have turbo's that are sized too small and will usually have more backpressure than boost pressure over much of the useable power-band. Car manufactures do this in an attempt to reduce turbo lag. When a turbocharger is too small, it will be a bigger restriction in the exhaust, causing more backpressure. A big mistake of turbo owners is to crank the boost up as high as they can thinking they are going faster, but in reality, chances are that they are just killing the efficiency of the turbo and most gains are lost.

If you want to run higher boost levels and backpressure is a problem, cam timing can be altered to give respectable power increases for much cheaper than a new turbocharger. Before you go increasing boost and changing cams, remember that the oxygen content into the engine will increase power, not boost pressure. A good flowing head with a good intercooler can make a lot of power without high boost. You may not need higher boost to get the power you want.

## Valve Overlap

If your one of many factory turbo car owners with a turbo sized too small, there will be higher exhaust pressure than intake, you should see that when both valves are open at the same time, the flow would reverse. Any valve overlap is a no no if you're looking for higher boost with a restrictive turbine housing. The exhaust valve will usually close very close to TDC, but there is still be more pressure on the cylinder than in the intake. You must allow the piston to travel down the bore until the pressure is equalized. If the cylinder pressure is lower than the intake manifold pressure, no reverse flow will take place. Using 0.050" lift figures, this means that the intake valve needs to open 20-35° ATDC, depending on the amount of boost you're using. Most street turbo's will work well when the valve opens close to 20° ATDC, only when boost gets near 30 psi will you need to delay it as much as 35° ATDC. In low boost applications (under 15 psi or so), opening the valve closer to TDC and maybe keeping the exhaust valve open a little after TDC is a compromise for better throttle response before the boost comes on. As you increase boost, you will need to delay the opening of the intake valve to avoid reversion.

You want the intake valve to open as soon as possible. In an ideal situation, the intake valve should open when the pressure in the cylinder is equal to boost pressure. This can cause a little confusion with cam overlap. If the exhaust valve closes before the intake opens, the overlap will be considered negative. If the exhaust valve closed at TDC and the intake opened at 20° ATDC there would be -20° of overlap. In this type situation, pumping losses are quite large, although the turbo will still use less power than a crank driven supercharger.

If you have a well-matched turbo for the engine and application, it is a different deal altogether. A well-matched turbine housing on the turbo will usually work well with cams with a lobe separation in the 112-114° area. If there is more pressure in the intake than in the exhaust, a camshaft suited for superchargers or nitrous usually works well. When the exhaust backpressure is lower than the intake, reversion is not a problem; actually just the opposite is a problem. More pressure in the intake can blow fresh intake charge right out the exhaust valve. This can be a serious problem with a turbo motor since the charge will burn in the exhaust raising temperatures of the exhaust valves and turbo. This is also a problem with superchargers, which is why supercharger cam profiles usually work well with turbo's.

In this type situation (boost being higher than exhaust backpressure), the power required to turn the turbine is nearly 100% recovered energy that would have normally been dumped out the tailpipe. Many will argue that nothing is free and you need pressure to spin the turbine and this must make pumping losses. They are wrong because a turbo is not getting anything for free at all; it is just making the engine more efficient. It is true that there are pumping losses, but on the other hand there are pumping gains as well. If the exhaust backpressure is lower than the intake, the intake pressure makes more force on the intake stroke to help push the piston down. At the same time another piston is on its exhaust stroke. So the intake pressure is more than canceling out the exhaust pressure. Not free, just more efficient.

## Valve Lift

By delaying the opening of the intake, the duration of the cam will be much shorter. A short duration intake works well with a turbo, but the problem is that sufficient lift is hard to get from such a short duration. This is where high ratio rockers can really pay off. A cam for a turbo engine can delay the intake opening by over 30° compared to a cam for a normally aspirated engine. This makes for much less valve lift when the piston is at peak

velocity (somewhere near 75° ATDC), any help to get the valve open faster will make large improvements.

## Roller Camshafts

Turbo engines place a large flow demand at low valve lifts, and roller cams cannot accelerate the valve opening as fast as a flat tappet. They do catch up and pass a flat tappet after about 20° or so, but up until that point the favor goes toward the flat tappet cam. The area where rollers really help in turbo motors (and supercharged) is cutting frictional losses. Any forced induction engine will need more spring force on the intakes. If you run a lot of boost, you'll need quite a bit more spring force to control the valves. As spring forces gets higher, the life of the cam gets reduced. A roller tappet can withstand more than twice the spring forces as a flat tappet with no problems.

On the exhaust side, it's not the springs that put the loads on the cam lobes. The problem there is that there is still so much cylinder pressure trying to hold that valve closed. This puts tremendous pressure on the exhaust lobes. So when high boost levels are used, consider a roller cam. I would definitely use a roller cam on engines making more than 20 lbs. of boost.

---

Source: [www.grapeaperacing.com](http://www.grapeaperacing.com)

# Turbocharger Exploded View

Source: [www.grapeaperacing.com](http://www.grapeaperacing.com)

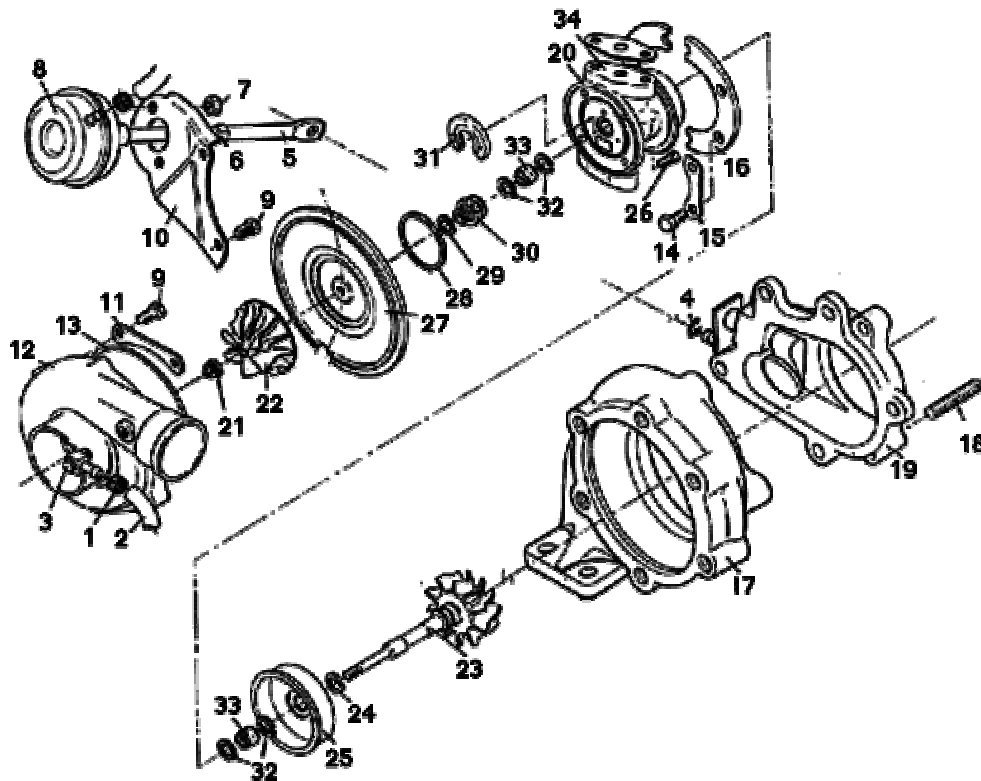

- |  |                                      |
|--|--------------------------------------|
| 1. Clamp                                   | 18. Exhaust Stud                     |
| 2. Hose (waste gate pressure bleed)        | 19. Waste gate housing               |
| 3. Fitting                                 | 20. Bearing housing                  |
| 4. Clip (waste gate lever)                 | 21. Nut (turbine shaft)              |
| 5. Rod (waste gate)                        | 22. Compressor                       |
| 6. Adjusting nut                           | 23. Turbine shaft                    |
| 7. Nut                                     | 24. Piston ring seal                 |
| 8. Control diaphragm (waste gate)          | 25. Heat shield                      |
| 9. Bolt                                    | 26. Bolt                             |
| 10. Bracket (waste gate control diaphragm) | 27. Compressor housing backing plate |
| 11. Locking plate (compressor housing)     | 28. O-ring                           |
| 12. Compressor housing                     | 29. Piston ring seal                 |
| 13. O-ring                                 | 30. Trust collar                     |
| 14. Bolt                                   | 31. Thrust bearing                   |
| 15. Locking plate (turbine housing)        | 32. Snap ring                        |
| 16. Clamp plate (turbine Housing)          | 33. Journal bearing                  |
| 17. Turbine Housing                        | 34. Oil drain gasket                 |

Source: [www.grapeaperacing.com](http://www.grapeaperacing.com)



# Turbocharger Troubleshooting Chart

Source: [www.grapeaperacing.com](http://www.grapeaperacing.com)

Problem	Possible Causes	Solutions
<b>Leaking or burning oil</b>	Plugged oil drain line	Clear oil drain line
	Worn bearings or bushings	Replace worn parts
	Bad seals	Replace seals
	Oil feed line or drain line (external leaks)	Replace gaskets or lines as necessary
<b>No or low boost pressure</b>	Waste gate stuck	Check for free operation of waste gate - replace bad parts
	Unit damaged	Replace damaged parts or replace unit
	Intake system not sealed	Check all clamps and ducting from the turbo to the engine
<b>Too much boost pressure (over boost)</b>	Waste gate not opening	Check for free operation of waste gate - replace bad parts
	Waste gate control valve damaged	Make sure control valve is operational
	Waste gate control diaphragm damaged	Replace diaphragm unit
	Waste gate too small for application (boost creeping higher as rpm goes up)	Replace the waste gate assembly, or the whole unit with one more suited for the engine
<b>Excessive noise under boost</b>	Worn bearings or bushings	Replace worn parts
	Damaged unit	Replace damaged parts or replace unit
	Intake system not sealed (air noise)	Check all clamps and ducting from the turbo to the engine
<b>Excessive turbo lag</b>	Worn bearing or bushings	Replace worn parts
	Damaged unit	Replace damaged parts or replace unit
	Unit too large for application	Replace unit with one more suited for the application
	Exhaust restriction	Replace bad exhaust parts
	Intake system not sealed	Check all clamps and ducting form the turbo to the engine
<b>Detonation under boost</b>	Too much boost pressure	Make sure waste gate and boost pressure bleed is ok
	Poor fuel quality	Use higher octane fuel
	Fuel system not capable of supplying enough fuel (lean mixture)	Either upgrade the fuel system or run less boost pressure
	Too much timing advance	Retard timing under boost
	Excessive intake charge heat	Run less boost or ad an intercooler

Source: [www.grapeaperacing.com](http://www.grapeaperacing.com)